

2-Wege Industriekugelhahn M1
2 way industrial ball valve

NEU
NEW

→ LIM 14 ⚡ ELE 15 | PNE 16

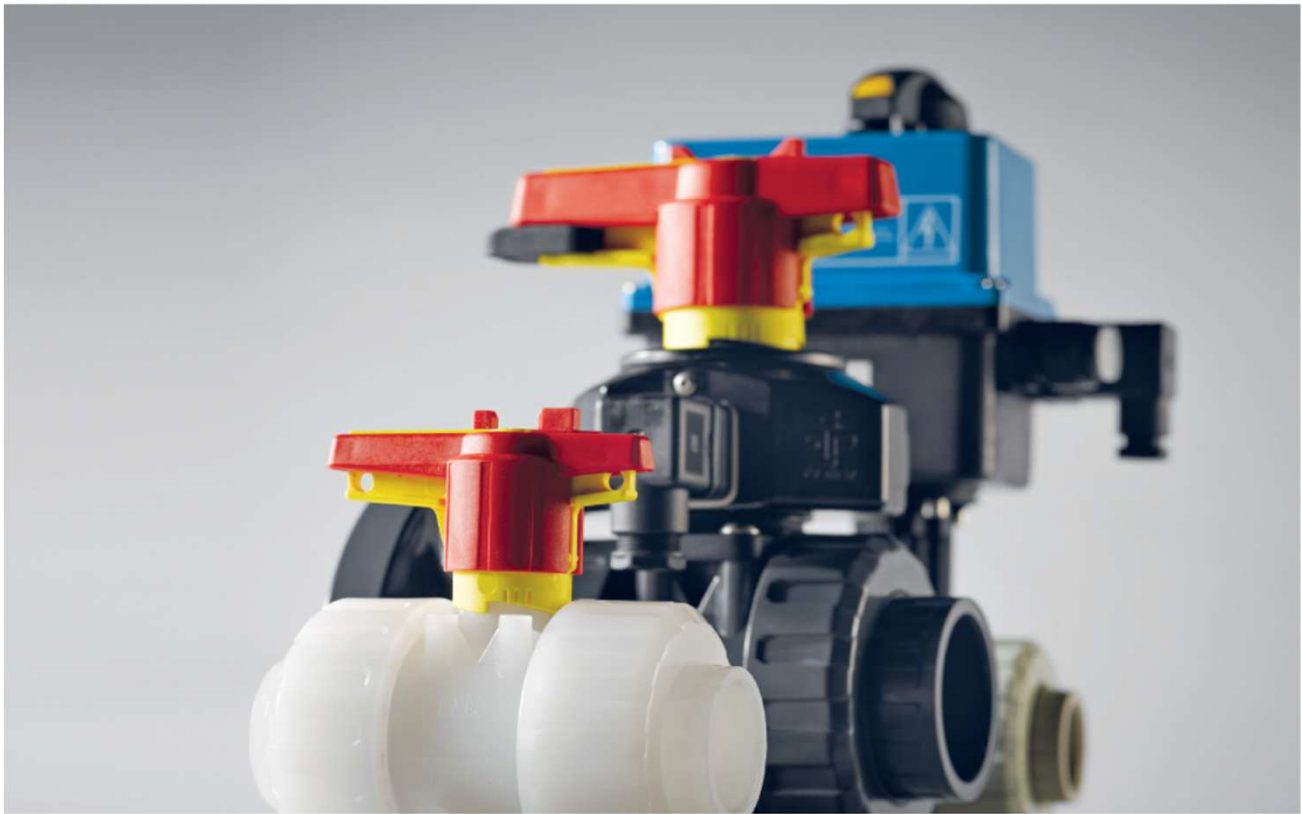

- Modularer Aufbau
- Silikonfrei
- Sägezahngewinde für einen perfekten Sitz der Überwurfmutter
- Standfuß für einfache Montage
- Im Gehäuse integrierte Dome für die direkte Montage des modularen Adaptersets
- PTFE-Sitz mit O-Ring
- Doppelt abgedichtete Welle
- Sicherheitsgriff mit dem Praher Labelling System
- Ausführung mit Kunststoffschrauben auf Anfrage

- Modular design
- Silicon-free
- Buttress thread for perfect fit of the union nut
- Integrated bracket for fix point mounting
- Integrated fixations for the modular adapter set: one-piece injected valve body
- Cushion O-Ring for PTFE seat
- Double sealed shaft
- Locking handle with integrated PLS (Praher Labelling System)
- Version with plastic screws (a.A.) available on request

- 1 Rückmeldungsset
Position Feedback
- 2 Adapterset
Adapter Set
- 3 Spann-/Distanzelement
Clamping/Spacing Element
- 4 Beschriftungsplättchen
Labelling Inserts
- 5 Kunststoffschrauben (a.A.)
Plasticscrews (on request)



2 way ball valve M1 manual with integrated Praher Labeling System



General:

- Material: PVC-U
- Seal material: EPDM / FPM
- Ball seating joint: PTFE
- Dimensions: DN10 – DN80
d16 – d100
d3/8" – d4"

Connection types:

- Solvent socket DIN / ASTM / JIS
- Solvent spigot DIN
- Threaded socket BSP / NPT
- PE fusion spigot DIN
- PE fusion socket DIN
- Fixed flange DIN / ANSI / JIS

Operating pressure:

PVC DN10 – DN80 PN16

Technical features:

- Silicone free
- Buttress thread
- Safety locking handle system
- Double axial gasket
- Floating ball
- Double sided blocked ball
- Adjustable ball seating joint
- Integrated fixations for bracket mounting
- Integrated bottom mounting stand
- Radial installation or removal
- Maintenance free

Accessories:

- Clamping / spacing element
- Adapter set*
- Position feedback for ball valve hand and automatic operated*

*see data sheet „M1 with Adapterset“ and „M1 with position indication“

SAFETY LOCKABLE HANDLE SYSTEM



This document does not constitute a guarantee, it is for initial information purposes only. The product range is continually upgraded, the designs and types therefore only reflect the state of the art at the time of printing. Subject to technical modifications!

Dimensions:

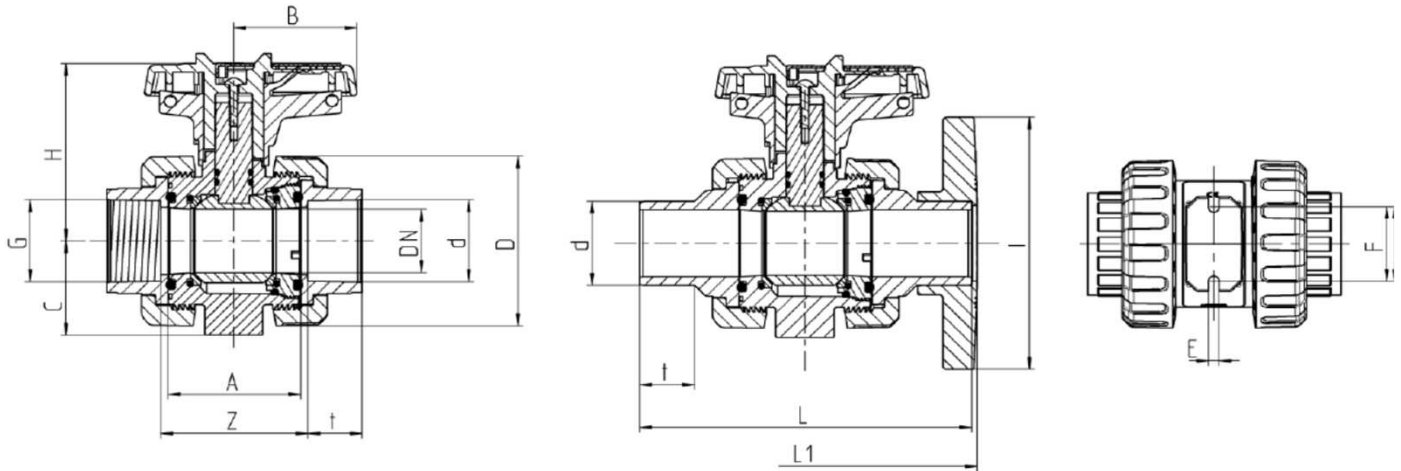

PVC-U

Connection types

PVC Solvent socket / Solvent spigot / Threaded socket / Fixed flange

PE Fusion spigot / Fusion socket

DN	10	15	20	25	32	40	50	65	80	80
d	16	20	25	32	40	50	63	75	90	110
G ¹ TSO	3/8"	1/2"	3/4"	1"	1 1/4"	1 1/2"	2"	2 1/2"	3"	4"
A	45	45	53,5	54	62	78	87	111,5	135,5	135,5
B	39,5	39,5	51	51	63,5	72	84	110	132	132
C	33	33	40	43	51	56	64	85	100	100
D	55,5	55,5	62	70	84	101	115	149	182	182
E	5,5	5,5	5,5	6,5	6,5	6,5	6,5	8,3	10,3	10,3
F	34	34	36	38	40	45	50	65	80	80
H	70,5	70,5	77	79,5	98	105,5	114	142	153	153
I	-	97	105	125	140	150	165	185	200	-
t _{SSO} ²	16	16,5	19,5	23	26,5	31,5	38,5	44,5	56,5	61
t _{SSP} ³	17	16,5	19,5	23	26,5	31,5	38,5	44,5	54	-
t _{FSP} ⁴ PE	13	14	15,5	18,5	15	29	31	32	30	-
t _{FSSO} ⁵ PE	14,5	16	17	19	21,5	25	29,5	34,5	38	42
Z _{SSO} ²	51	50	59,5	60	68,5	86	98	122	152,5	162
Z _{TSO} ¹	48	50	60	60	68	87	98	122	156	-
Z _{FSP} ⁵ PE	52,5	50	62	64,5	75	97	110,5	139,5	181,5	185,5
L _{SSP} ³	98	123,5	143,5	153,5	173,5	193,5	223,5	259,5	297	-
L _{FSP} ⁴ PE	95	106,5	126,5	131	120	162,5	175	227	265,5	-
L1 _{FF} ⁶	-	130	150	160	180	200	230	266	307,5	-
PN	16	16	16	16	16	16	16	16	16	16

Dimensions in mm

¹ TSO = Threaded socket

² SSO = Solvent socket

³ SSP = Solvent spigot

⁴ FSP = Fusion spigot

⁵ FSSO = Fusion socket

⁶ FF = Fixed flange

- = currently not released

Diagrams:

Pressure - Temperature

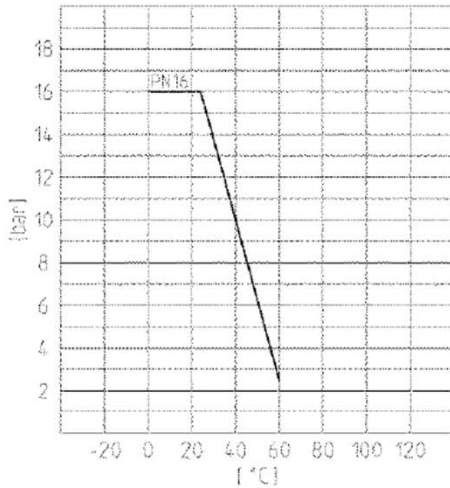

Pressure loss

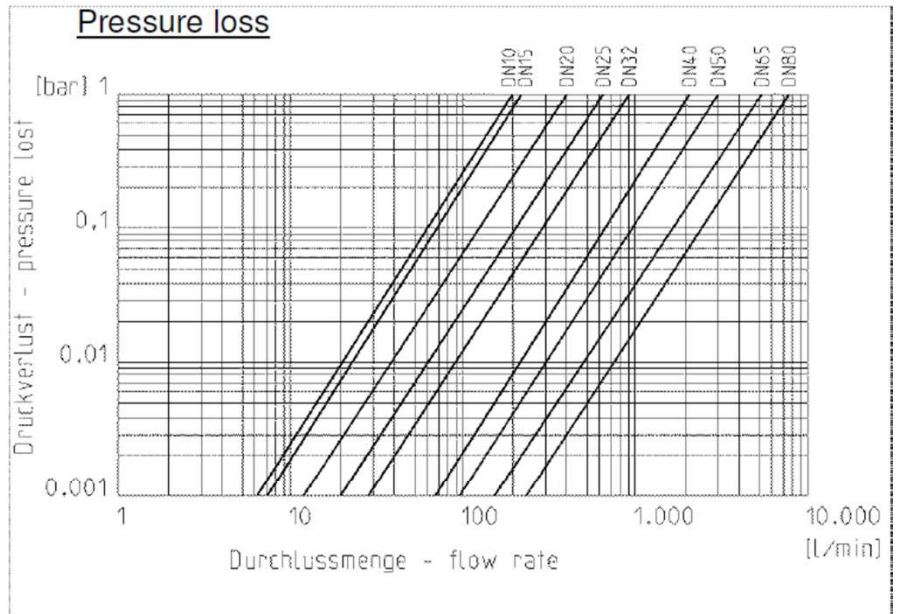

Cv value table

Pressure loss	DN10 d16	DN15 d20	DN20 d25	DN25 d32	DN32 d40	DN40 d50	DN50 d63	DN65 d75	DN80 d90	DN80 d110
0,001 bar	6,2	7,1	12,6	19,9	28,4	67	94,8	162,8	240,3	240,3
1 bar	198	225	400	630	900	2120	3000	5150	7600	7600

Angaben in l/min (PN16 Rohr)

Torque

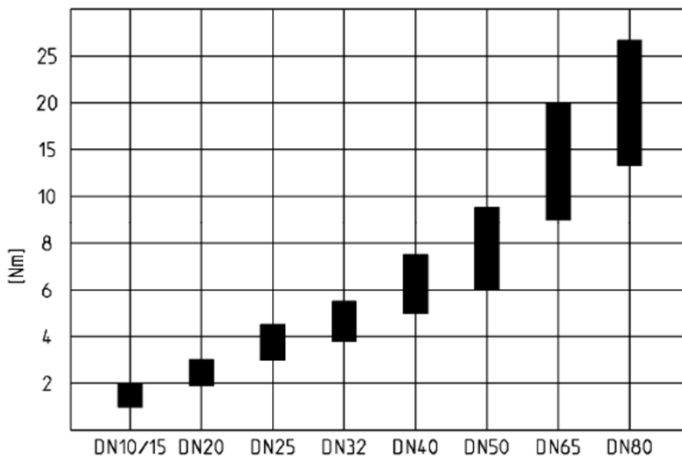

Flow characteristic

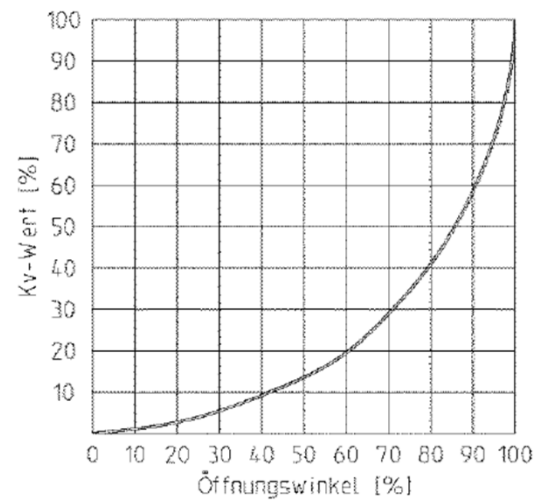

Exploded drawing:

- | | |
|---|---|
| 01. Labeling plate | 10. Ball |
| 02. Screw | 11. O-Ring |
| 03. Handle | 12. Thrust collar |
| 04. Spring loaded locking sleeve | 13. O-Ring |
| 05. O-Ring | 14. Connector types
Solvent socket / - spigot
Threaded socket
Fusion socket /- spigot |
| 06. Shaft | 15. Union nut |
| 07. Body | |
| 08. O-Ring | |
| 09. Ball seating joint | |

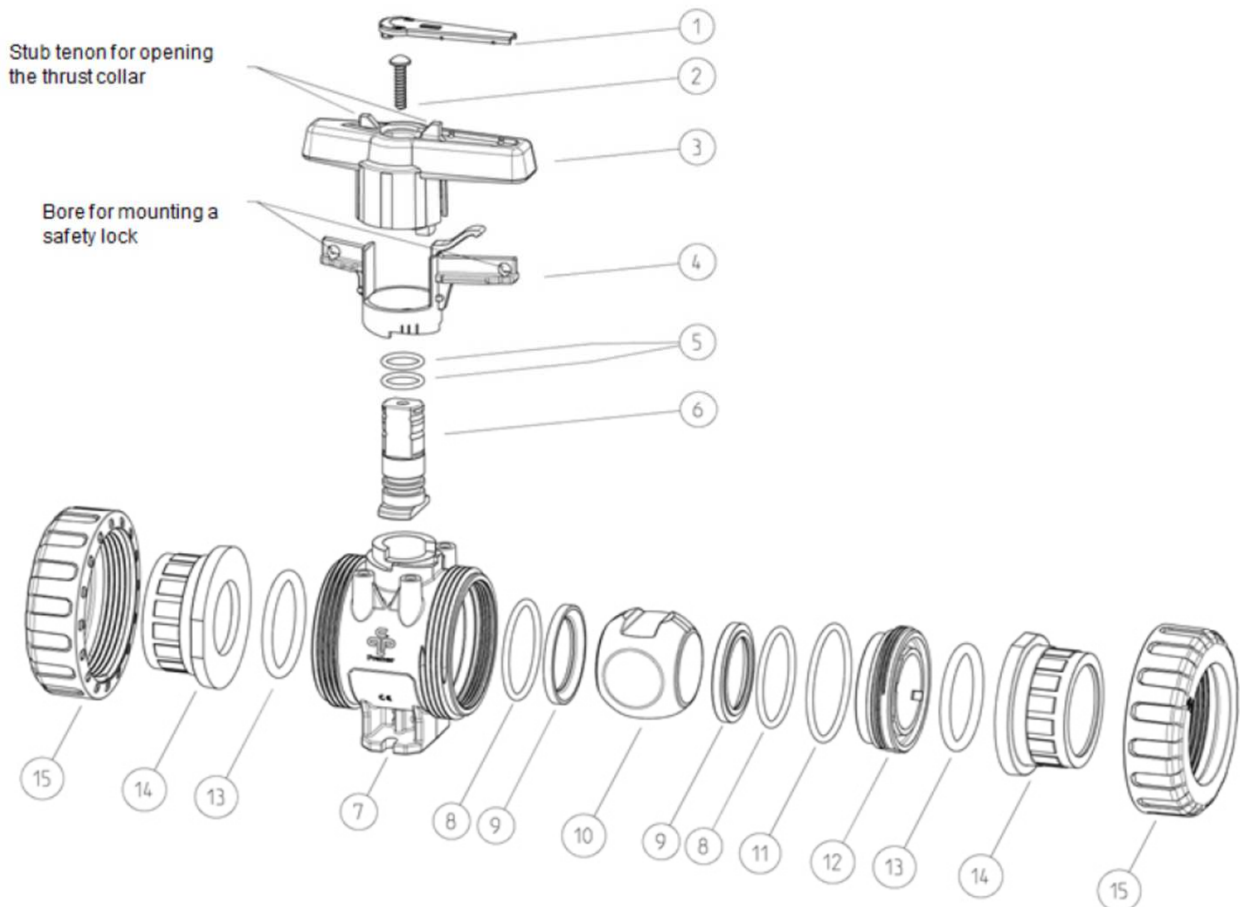

Bottom mounting stand – mounting possibilities:

- Assembly rail

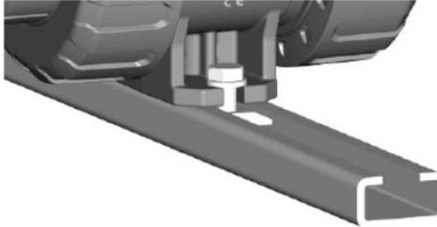

- Plate

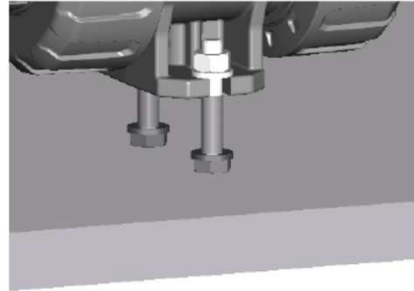

- Masonry / Concrete
 - Hanger screw and dowel required



PLS – Praher Labeling System



Technical features:

- Clear and durable label
- Convenient marking by touch-up pen or laser engraving
- Standard version available with yellow plate; other colors available in red, blue and green
- Simple and easy to change
- Corrosion-resistant
- No effect on the function of the handle

Accessories

Clamping / spacing element:

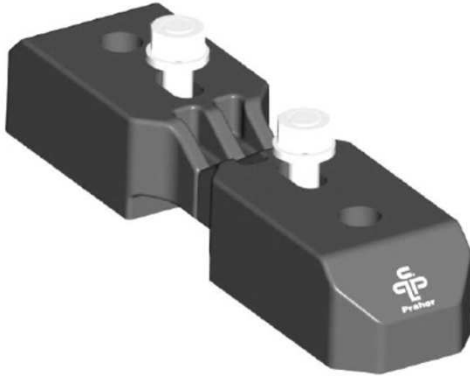

Technical features:

- Using for fixing as:
 - Clamping element
 - floors, walls, ceilings
 - plate
 - Spacing element
(screws additionally necessary)
 - for flange connection
- Bore for threaded bush

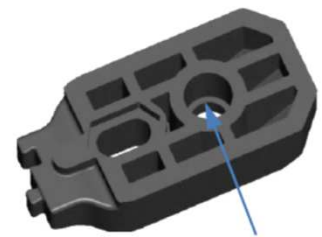
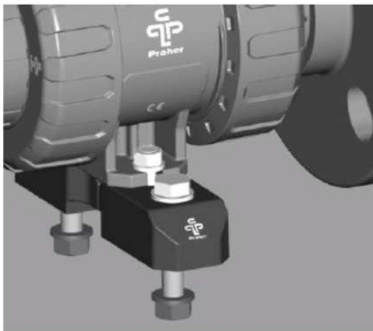

Bore for threaded bush

Dimensions:

Use as clamping element

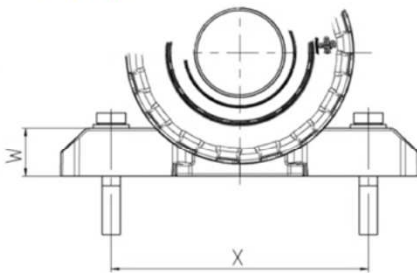

Use as spacing element

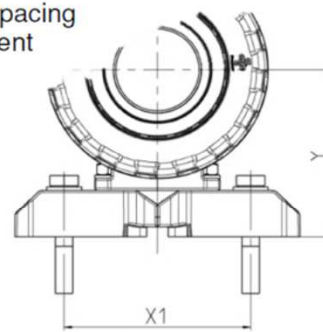

DN	10	15	20	25	32	40	50
d	16	20	25	32	40	50	63
T	54	54	54	65	65	65	65
U	25	25	25	32	32	32	32
V	6,5	6,5	6,5	8,5	8,5	8,5	8,5
W	16	16	16	22	22	22	22
X	90	90	94	107	109	114	119
X1	70	70	70	85	85	85	85
Y	49	49	56	65	73	78	86

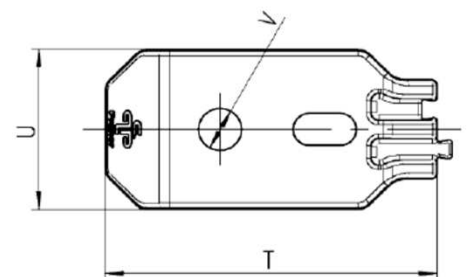

Dimensions in mm

Adapter set for automatisation:



Technical features:

- Adapter set for mounting of actuator and position feedback
- Coupling – actuator
- Material bracket and coupling: PA-GF
- Includes stainless steel bolts

Dimensions:

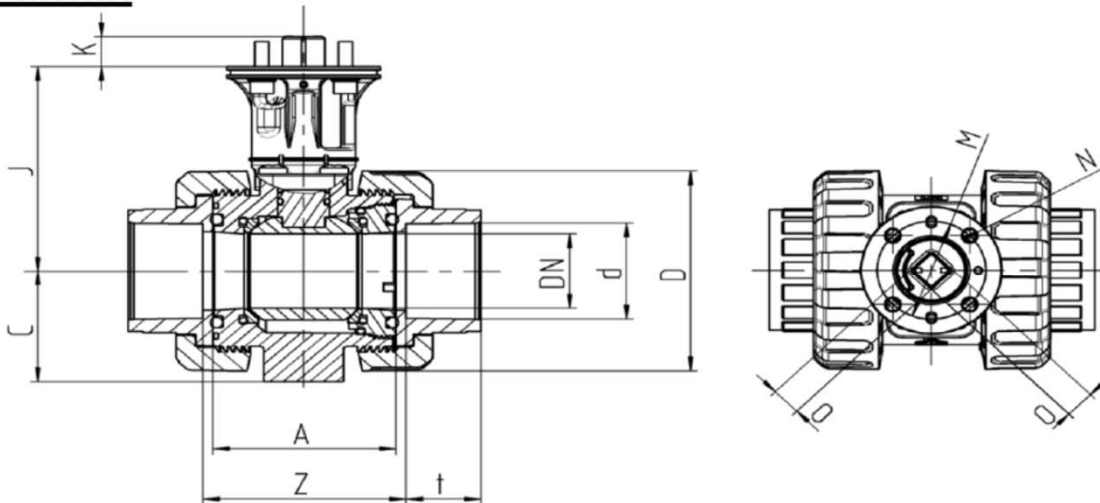

Connector type
PVC solvent socket

DN	10	15	20	25	32	40	50	65	80	80
d	16	20	25	32	40	50	63	75	90	110
ISO Flange	F04	F04	F04	F04	F05	F05	F05	F07	F07	F07
A	45	45	53,5	54	62	78	87	111,5	135,5	135,5
C	33	33	40	43	51	56	64	85	100	100
D	55,5	55,5	62	70	84	101	115	149	182	182
J	80	80	85,5	88	97	103	109,5	136,5	159,5	159,5
K	11	11	11	11	15	15	15	18	18	18
M	42	42	42	42	50	50	50	70	70	70
N	5,5	5,5	5,5	5,5	6,5	6,5	6,5	8,5	8,5	8,5
O	11	11	11	11	11	14	14	17	17	17
t	16	16,5	19,5	23	26,5	31,5	38,5	44,5	56,5	61
Z	51	50	59,5	60	68,5	86	98	122	152,5	162
PN	16	16	16	16	16	16	16	16	16	16

Dimensions in mm

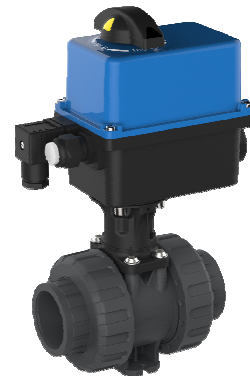
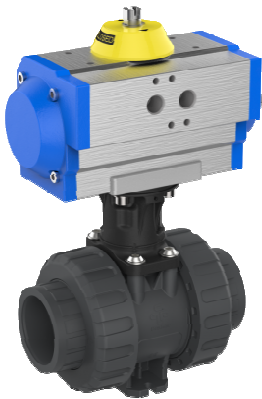

Other accessories:



SWITCHBOX



SOLENOID VALVES



PNEUMATIC OR ELECTROPNEUMATIC POSITIONERS